

# Prevent Reverse Charging of a Lithium Battery to Meet UL Safety Requirement

## Introduction

Lithium batteries are commonly used in many applications with devices requiring backup power, such as Real Time Clock (RTC) and memory devices.

Whenever lithium batteries are not the single power source in a circuit, there is risk of fire or explosion if the battery is accidentally connected with an electrical power source that would charge the battery.

This application note provides information needed for connecting Lithium batteries in backup power switching circuits such that the circuit meets Underwriters Laboratories (UL) standards. Specifically, UL standard 60950-1 describes the guidelines for Lithium batteries.

## Protection Circuit

### Protection Circuit for Intersil’s RTCs with Battery Switchover Feature

All Intersil’s RTCs with a Battery Switchover feature, such as the ISL12026 series, have internal protection circuit to prevent reverse charging. Figure 1 shows the internal protection circuitry illustrating the complementary control which disables one supply input while enabling the other. The two series MOSFET switches provide safe switching with redundancy. There is also a path from V<sub>DD</sub> to V<sub>BAT</sub> through a MOSFET (M1) used to pull-up the V<sub>BAT</sub> switch gate, and two 200Ω resistors (R1 and R2). If the M1 gate is shorted, the current through resistors R1 and R2 limits the charging current to the Lithium battery (Up to 9.25mA for V<sub>DD</sub> = 5.5V, V<sub>BAT</sub> = 1.8V).

(A detailed schematic of the battery switchover control block is available upon request.)

In order to meet full UL safety requirements, a series Schottky diode needs to be added to the V<sub>BAT</sub> input for these products. The external diode is used to provide

protection in the event that the internal MOSFET and series resistors should fail. Figure 2 shows the actual circuit with the external protection diode. (Note that a high value series resistor would provide similar protection, but would limit normal operating range.)

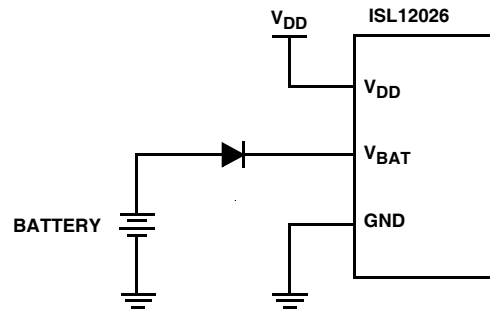

FIGURE 2. PROTECTION CIRCUIT WITH AN EXTERNAL DIODE)

Only use a silicon diode or Schottky diode having a low reverse current. A typical maximum reverse current of 1μA is recommended by UL. A few diodes that can be used that exhibit low reverse current include, but are not limited to, the BAS40, BAS70, and BAT54 diodes.

The reverse current can also be calculated for a specific battery. The maximum reverse current of the diode for a specific battery is given in Equation 1:

$$I_r = \frac{I_c}{T} \times 10^6 \quad \text{(EQ. 1)}$$

where I<sub>r</sub> is the maximum reverse current in μA, I<sub>c</sub> is the total allowable charging amount of a battery in mAh, and T is the total usage time in hour.

I<sub>c</sub> is given in Equation 2:

$$I_c = Q_{xtp} \quad \text{(EQ. 2)}$$

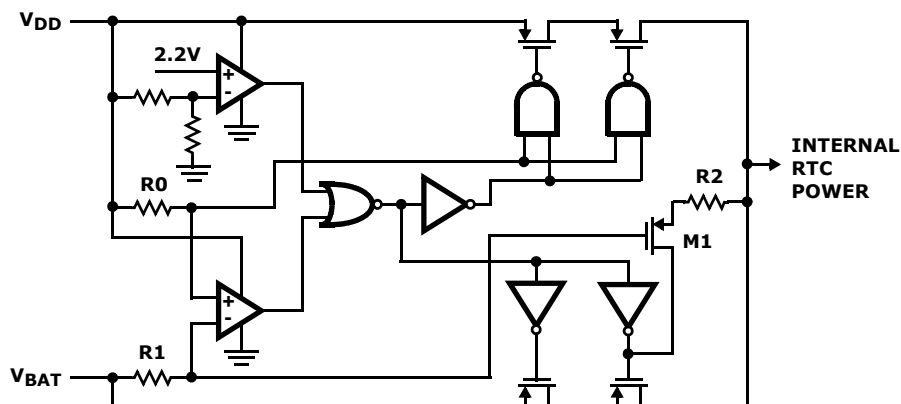

FIGURE 1. SIMPLIFIED BATTERY SWITCHOVER CIRCUIT

## Application Note 1535

where  $Q$  is the nominal capacity of the battery in mAh and  $t_p$  is the total allowable charging period in percent. For coin type battery,  $t_p$  is 3%. For cylindrical battery,  $t_p$  is 1%.

Example: A 1000mAh coin-type battery is to be used for five years.

With Equation 2,  $I_c$  is 30mAh (1000mAh x 3% (coin-type battery) = 30mAh).

With Equation 1, a diode with a reverse current of  $0.7\mu\text{A}$  or less is required ( $30\text{mAh} \div \text{usage period (5 years} \times 365 \text{ days} \times 24 \text{ hours)} = 0.7\mu\text{A}$ ).

### Protection Circuit for Other Devices Without Internal Protection

For circuits that require a battery backup feature but either do not have a  $V_{\text{BAT}}$  pin or the  $V_{\text{BAT}}$  pin does not offer reverse charging protection, then a classic UL recommended three diode configuration is the best protection against reverse charging.

For example, the ISL12058 does not offer a battery switchover feature but an application requires it. The battery backup function can be added simply by connecting both main supply and backup battery to the  $V_{\text{DD}}$  pin. To have proper protection, a diode is placed in series with the main supply and two diodes are placed in series with the battery. The diode in series with the main supply is to block current from the battery into the main supply. Two diodes in series with the battery are to prevent reverse charging. The second diode is used to provide protection in the event that one should fail. Figure 3 shows the actual circuit with three diodes protection.

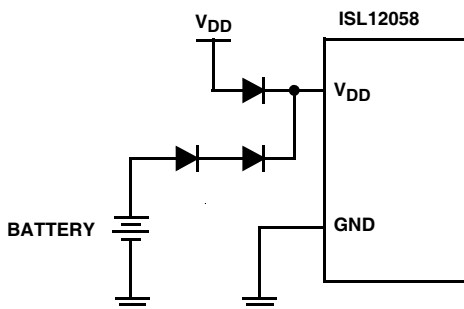

FIGURE 3. PROTECTION CIRCUIT WITH THREE DIODES

### Testing

To insure the protection diodes are properly installed for the reverse charging protection, a simple test sequence is required after installation of the diodes.

A forced reverse charging test is done to insure the diodes are placed correctly to prevent reverse charging current to the battery. This is done by taking  $V_{\text{DD}}$  to 3.6V. The battery input is then forced to 1.8V and the charging current is checked with an ammeter capable of measuring current as low as 100nA to insure that it does not exceed the maximum reverse current of the protection diode. The test circuit is shown in Figure 4.

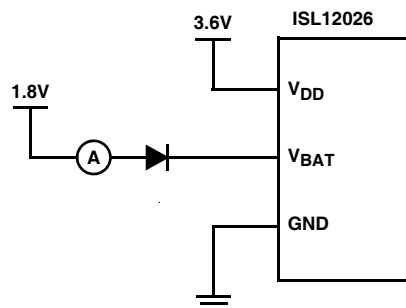

FIGURE 4. TEST CIRCUIT FOR REVERSE CHARGING PROTECTION

### Conclusion

Lithium batteries are commonly used in a wide range of applications with devices requiring backup power, such as RTCs and memory devices. In order to meet UL standards for maximum charging (leakage) current, extra circuitry is required such as low leakage diodes even though a protected device has internal reverse charging protection. For a system with supplies other than the lithium battery, diode protection is not required but may be put in place to prevent any reverse charging from occurring.

### Appendix

- Intersil devices that require one diode in series (Figure 2 on page 1) with the  $V_{\text{BAT}}$  pin for UL requirements: ISL1208, ISL1209, ISL1218, ISL1219, ISL1220, ISL1221, ISL12020, ISL12020M, ISL12022, ISL12022M, ISL12024, ISL12025, ISL12026, ISL12027, ISL12028, ISL12029.
- Intersil devices that require two diode in series (Figure 3) for UL requirements: ISL12057, ISL12058, ISL12059.